

LED MEMO2

IP40



SURFACE LED CORRIDOR LUMINARY

APPLICATION AREA:

Self testing emergency luminaries for use to the outdoor spaces of the vessel.

DESIGN:

According to the rules of international classification societies, VDE and IEC.

HOUSING:

Polycarbonate.
Diffuser made of clear polycarbonate.

LAMPS:

LED Module.

MOUNTING:

Wall or ceiling installation.

ELECTRIC:

230V 50 or 60Hz,
Flexible cable, heat resistant up to 105°C.

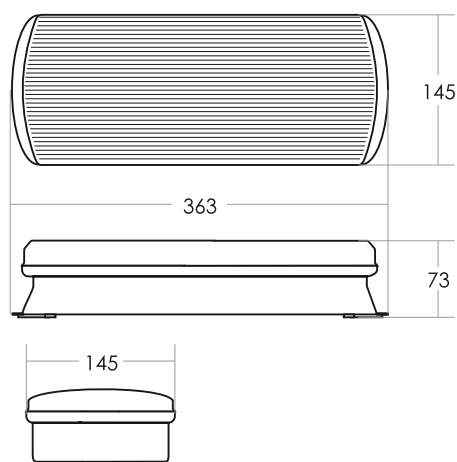

ORDER CODES:

OPERATION VOLTAGE	220-240V AC/ 50-60Hz
MAXIMUM POWER CONSUMPTION	3,5W/7,5VA
BATTERY (Ni-Cd)	3,6V/ 1,5Ah
BATTERY PROTECTION	From overcharge and full discharge
INDICATION - CONTROLS	Charge, Indication LED, Test button
CHARGING TIME	24H
MINIMUM AUTONOMOUS DURATION	180 min
ILLUMINATION SOURCE	15 white LEDs
ILLUMINATION (230V/EMERGENCY)	105/105 lm
DEGREES OF COVER PROTECTION	IP40

MARINE LUMINAIRES