



IP40

# MEM03 LED

## OUTDOOR EMERGENCY LUMINAIRES

### APPLICATION AREA:

Self testing emergency luminaires with LEDs for use to th.

### DESIGN:

According to the rules of international classification societies, VDE and IEC.

### HOUSING:

Polycarbonate.  
Diffuser made of clear polycarbonate.

### LAMPS:

LED module.

### MOUNTING:

Wall or ceiling installation.

### ELECTRIC:

230V 50 or 60Hz,  
Flexible cable, heat resistant up to 105°C.

### PROTECTION:

IP40.

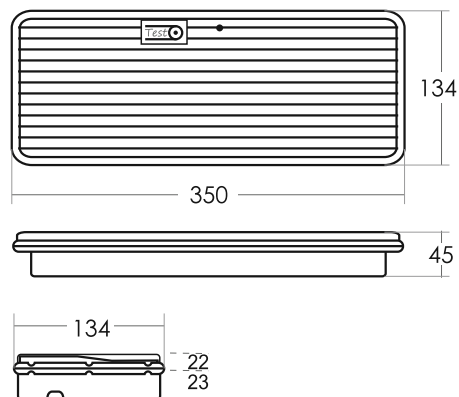

### ORDER CODES:

OPERATION VOLTAGE	220-240V AC/ 50-60Hz
MAXIMUM POWER CONSUMPTION	3,5W/7VA
BATTERY (Ni-Cd)	3,6V/ 1,5Ah
BATTERY PROTECTION	From overcharge and full discharge
INDICATION - CONTROLS	Charge, Indication LED, Test button
CHARGING TIME	24H
MINIMUM AUTONOMOUS DURATION	180 min
ILLUMINATION SOURCE	15 white LEDs
ILLUMINATION ( 230V/EMERGENCY)	105/105 lm
DEGREES OF COVER PROTECTION	IP40